

HC49US Low Profile

MICROPROCESSOR CRYSTALS / RESISTANCE WELD

SPECIFICATION

| | |
|-------------------------------------|--------------------------|
| Frequency Range | 3.579545 to 60.000 MHz |
| Frequency Tolerance | ± 50 PPM (Standard) |
| Frequency Stability @ 25EC | ± 50 PPM (Standard) |
| Operating Temperature Range | 0EC to 70EC (Standard) |
| Load Capacitance (C _L) | 12pF to 50pF or Series |
| Shunt Capacitance | 7pF Maximum |
| Drive Level | 1mWatt Maximum |
| Aging | ±5 PPM per year Maximum |

Dimensions in mm

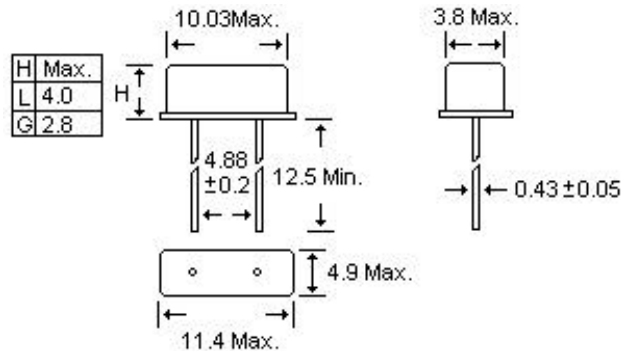

HC49US Part Number Break Down

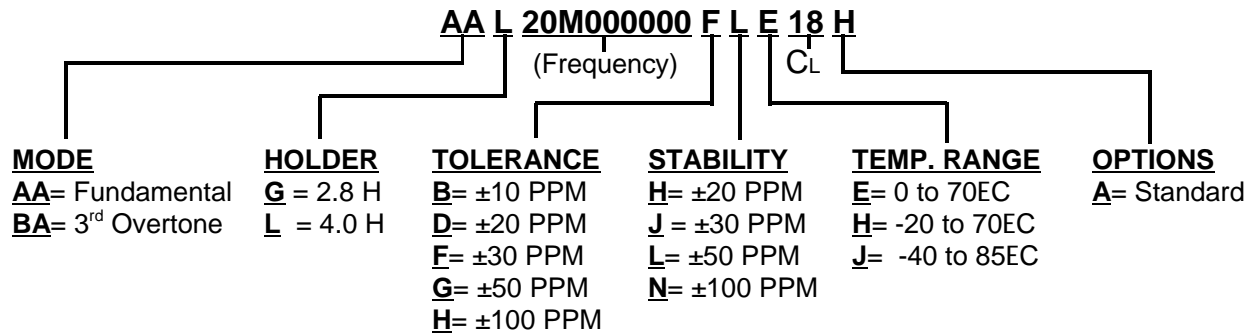

Standard Crystal Corporation 9940 E. Baldwin Place, El Monte, Ca., 91731

Phone: (800) 423-4578, Fax: (626) 443-9049

www.standardcrystalcorp.com, E-Mail: stdxtl@pacbell.net